

Scale Manufacturers Association

**Load Cell
Application and Test
Guideline**

Approved
April 2008

Scale Manufacturers Association
6724 Lone Oak Blvd.
Naples, Florida 34109
Phone: 239-514-3441

Load Cell application and Test Guideline

Table of Contents

Section

- 1 Purpose
- 2 Scope
- 3 Introduction to Load Cells
- 4 Load Cell Specifications
- 5 Test Procedures

Appendices

- I Comparison of load cell specifications
- II Load cell functional testing
- III Load cell Terminology

References

The following individuals, representing the membership of the SMA, contributed to this standard:

Cardinal Scale Manufacturing Company	Steve Patoray
HBM Inc.	Jeff Robidoux
Hobart	Nigel Mills
Mettler-Toledo Inc.	Darrell Flocken
Mettler-Toledo Inc.	Tom Leahy
Revere Transducers Inc.	Jan Kersten
Tedea-Huntleigh Inc.	Quenton Olson
Avery Weigh-Tronix Inc.	Kevin Fruechte

1. Purpose

1.1. It is the purpose of this guideline to promote greater understanding between manufacturers and users of load cells by establishing uniform terminology, method of specification, and test procedures for load cells.

1.2. A primary objective of the standard is the establishment of simple and readily understandable definitions. As much as possible, terminology has been defined in a manner such that the term can be expressed quantitatively and in a straightforward manner.

1.3. It is also an objective of the standard to establish a common term or title for each performance characteristic relating to load measuring devices. Where several terms pertaining to the same definition are in common usage, preference will be indicated by listing the definitions under the preferred term.

1.4. All terms for which a definition has been provided, with the exception of “load” and “load cell”, are shown **bold** throughout to facilitate referencing the definitions.

1.5. It will be noted that the term “**accuracy**” has been used sparingly since its meaning has become too general. When applied to measuring devices, this term is confusing since it is seldom known which specific errors are included.

2. Scope

2.1. This standard provides recommended terminology and definitions pertaining to load cells used for performing accurate measurement of weight and force.

2.1.1. Whenever possible the terminology and definitions have been established to apply as broadly as possible to all load cells regardless of technology employed. However, the main focus has been on stress or strain sensing load cells and specifically **strain gage load cells** and terminology pertaining exclusively to other load cell types (mechanical, hydraulic, pneumatic, etc.) has not been included.

2.1.2. The terminology and definitions in this document refer to load cells only. No attempt has been made to cover related instrument systems terminology.

2.1.3. It is recognized that there is additional transducer terminology that could apply to load cells. However, the list of definitions in Appendix III has purposely been limited to those terms frequently used and necessary in the general use and application of such devices.

3. Introduction to Load Cells

3.1. A load cell is a device that is used to measure weight or force. When a force is applied to it in a specific manner, a load cell produces an output **signal** that is proportional to the applied force. **Strain gage load cells** are at the heart of the majority of weighing and force measurement devices produced today. One end of a load cell is typically supported on a rigid structure while the other end supports a load-receiving device through which the load or force is applied. Load cells can be used individually or in combinations in weighing devices, as dictated by the geometry of the object to be weighed.

3.2. **Strain gage load cells** are by far the most common form of load cell commercially available today, and are briefly described here. Figure 1 illustrates a typical metallic foil strain gage.

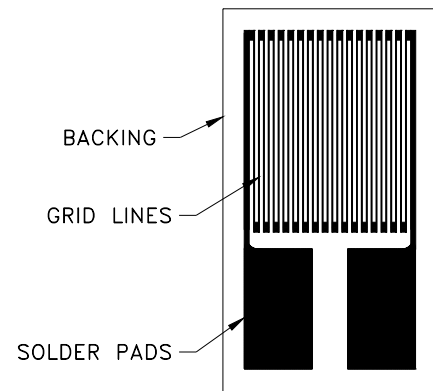

Figure 1: Metallic foil strain gage

This consists of a metallic foil etched into parallel grid lines forming a circuit between the solder pads that are used to complete the circuit. The foil is bonded to an insulating backing material that, in turn, is bonded to the surface of the load cell, as shown in Figure 2. A Strain gage type load cell consists of a spring element that is selectively weakened to create regions of relatively high strain; this is where the strain gages are applied.

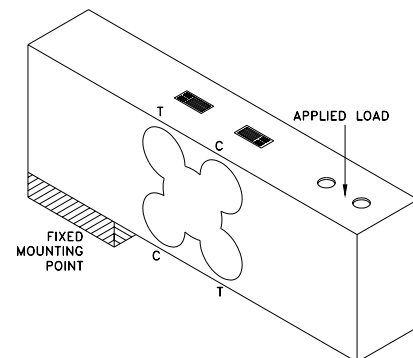

Figure 2: Strain gage arrangement on a load cell

In Figure 2, two gages are illustrated on the top surface and two corresponding gages on the bottom surface are not shown. In this arrangement two gages measure tensile strains and two measure compressive strains as load is applied to the load cell (indicated by the letters T and C respectively in Figure 2). The strain gages are wired together to form a **Wheatstone bridge**, as illustrated in Figure 3.

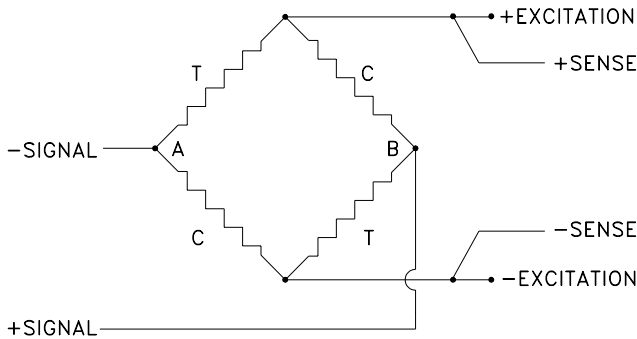

Figure 3: Wheatstone bridge

Note that several other resistors are typically included in the circuit, for example, a resistor may be added to temperature compensate the cell's performance, these are not shown for simplicity. A stable **excitation voltage** is applied to opposite corners of the **Wheatstone bridge**, and a **signal** is measured across the others, points A and B in Figure 3. With no load applied to the cell, all gages have the same resistance and hence there is no voltage difference between points A and B. As load is applied to the cell, the resistance of the tension gages increases, while that of the compression gages decreases. The bridge now becomes "unbalanced" and a voltage difference (**signal**) proportional to applied load can be measured across points A and B. Electronic weight indicators are readily available which, at their most basic, supply the **excitation voltage** for the bridge, measure the output **signal**, and provide a digital display of the applied load. Some load cells and indicators have provision for **sense** wires as shown in Figure 3 which allow the indicator to measure and adjust for the actual **excitation voltage** applied to the cell, this is particularly important with long cable runs.

3.3. Several mechanical configurations of load cell have evolved for different applications; here is a brief description of the most common:

3.3.1. Figure 4 illustrates a tension canister cell, and Figure 5 illustrates a typical S-beam, the arrows indicate the direction of applied loading.

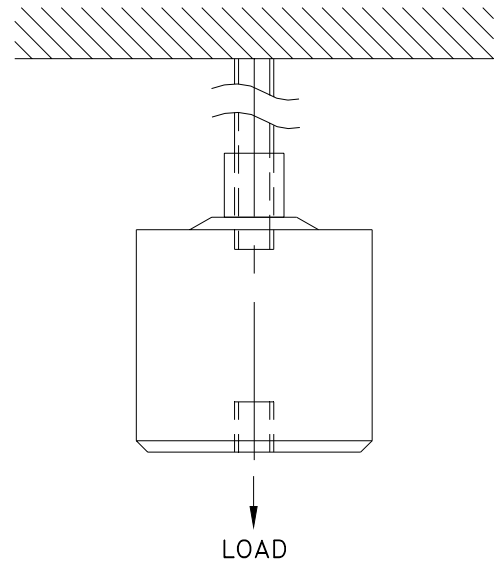

Figure 4: Canister type load cell

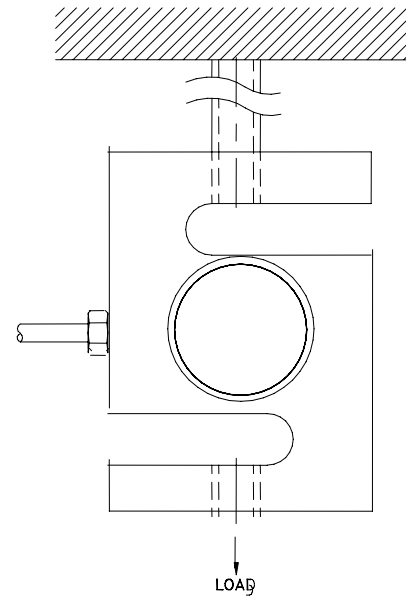

Figure 5: S-beam load cell

These are often used in tank and hopper weighing, where the load cells are suspended from an overhead structure and the object to be weighed is hung from the underside. The S-beam is also widely used in the conversion of mechanical scales to electro-mechanical; in this situation the cell is used to sense the tension in the steelyard rod connecting the lever system to the beam. Typical capacities range from 100 lb to 50,000 lb for tension canisters, and 25 lb to 20,000 lb for S beams.

3.3.2. Figure 6 illustrates a compression canister cell; Figure 7 illustrates a low profile compression disk cell, while Figure 8 illustrates a rocker column cell. These cells are cylindrical in shape and used in compression

applications. The relationship of the distance between the bearing points of contact and the spherical radius of the bearing surface determine self-restoring alignment characteristics of this design approach. Other load cells such as canister and S-beam geometries can also be adapted for use in a rocker configuration to improve accuracy in certain scale designs.

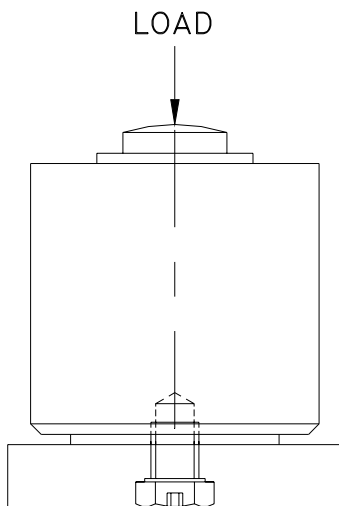

Figure 6: Canister load cell

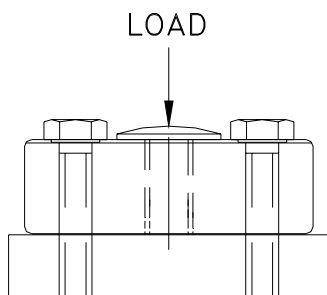

Figure 7: Compression disk load cell

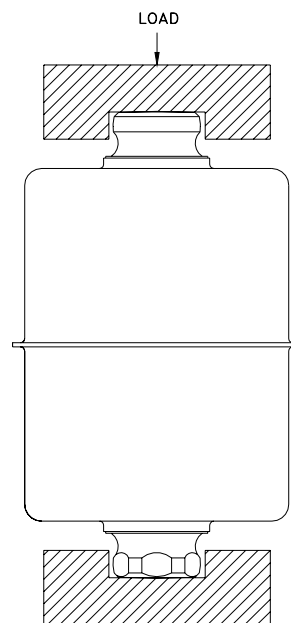

Figure 8: Rocker column load cell

All of these cells are used in vehicle scales. The rocker column is designed so that it will return to an upright position after the deck has been disturbed laterally, eliminating the need for check rods. The canister and disk cells are also used in tank and hopper scales. Typical capacities range from 500 lb to 500,000 lb for compression canisters, 1,000 lb to 100,000 lb for compression disks, and 1,000 lb to 200,000 lb for rocker columns.

3.3.3. Figures 9 and 10 illustrate two forms of double-ended shear beam.

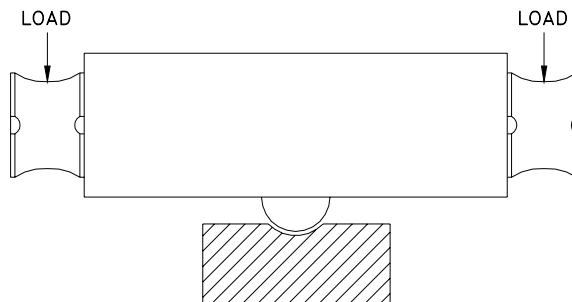

Figure 9: Double-ended shear beam

The cell illustrated in Figure 9 is supported at its center while the load is suspended from the ends through links hanging from the “ears”. This cell is typically used in vehicle scales. Figure 10 illustrates a similar cell supported at each end while the load is introduced at the center.

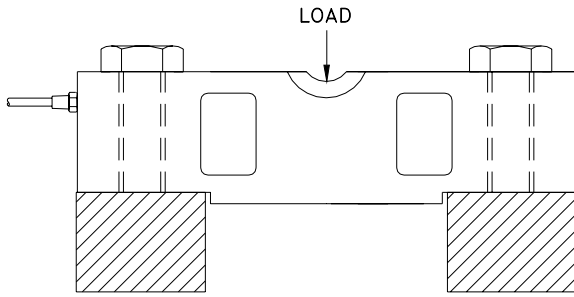

Figure 10: Double-ended shear beam

For vehicle scale applications the load is typically introduced through a link hanging at the center. This cell is also used for tank and hopper weighing, in which case the load is introduced at the center through a clamp arrangement that also provides lift off protection. Double-ended shear beams typically range in capacity from 1,000 lb to 250,000 lb.

3.3.4. Figure 11 illustrates a single ended beam that is widely used in floor scales and tank and hopper weighing.

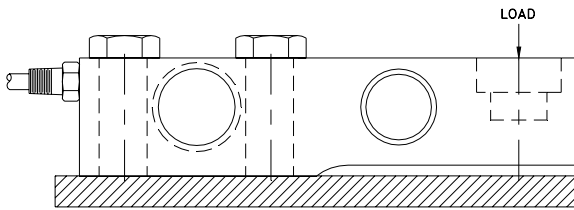

Figure 11: Single-ended beam

The load can be introduced through a rocker pin or ball and cup arrangement. There are many configurations of single ended beams, with capacities typically ranging from 10 lb to 50,000 lb.

3.3.5. Figure 12 illustrates a single point load cell that is widely used in small platform scales.

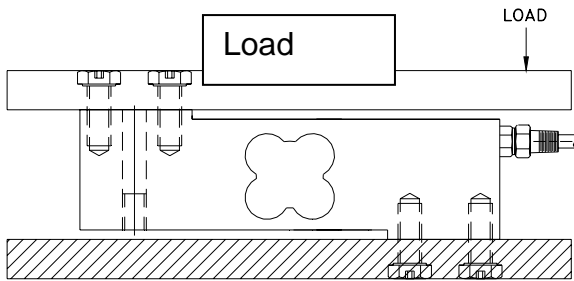

Figure 12: Single point load cell

Single point cells differ from the other cells described thus far in that it is moment insensitive, meaning that it reads the same regardless of where the load is applied to the upper platform. Capacities typically range from 2 lb to 4,500 lb and can accommodate platform sizes up to 48 inches square.

3.4. Load Cell Deflection

All load cells are subject to stress due to the load applied and are therefore subject to strain as described above in the strain gage section. There is a necessary deflection associated with a given strain. Load cell deflection at rated capacity can vary from a few thousandths of an inch up to a tenth of an inch or perhaps more. The weighing system designer must consider a number of factors related to load cell deflection or stiffness. There are two factors involved in load cell stiffness considerations:

The spring equation or Hooke's law relates the force exerted by a spring to the distance it is stretched by a spring constant, k , measured in force per length:

$$F = k\delta$$

Where F is the force of the applied gross load, k is the spring constant and δ is the cell displacement. The fundamental resonant frequency of a spring/mass system with the load cell as spring and the gross load applied to the spring as mass is given by:

$$f(\text{Hz}) = \frac{1}{2\pi} \sqrt{\frac{k}{M}}$$

Where f is the resonant frequency (Hz) and M is the applied gross mass. Combining the two equations, we get the useful formula:

$$f(\text{Hz}) = \frac{1}{2\pi} \sqrt{\frac{g}{\delta}}$$

Where g is the acceleration due to gravity in appropriate units.

The weighing system designer needs to consider the tradeoff involved in the inverse relationship between resonant frequency and deflection.

A stiffer cell will provide a higher resonant frequency for the system. This higher resonance will allow improved better settling and filtering characteristics with potentially shorter times to an accurate weight (for a check weigher for example). A stiffer cell is, however, more difficult to protect from shock and overload conditions.

4. Load Cell Specifications

4.1. Load cells are available with various **accuracy** levels to suit an array of industrial and **legal for trade (LFT)** weighing applications. A **LFT** application is one where the load cell or scale is used in commercial transactions to determine the charge for goods or services rendered. The performance requirements for **LFT** load cells are well defined in standards that are adhered to within the weighing industry. There has been considerable progress in recent years in rationalizing the requirements for **LFT** load cells across the World; here is a description of two of the more widely accepted standards.

4.1.1. Specifications, Tolerances, and Other Technical Requirements for Weighing and Measuring Devices (better known as Handbook 44) is the document used by Weights and Measures jurisdictions as the basis for exercising control over scales (and hence load cells) in the USA and some other countries, notably in Central and South America. Handbook 44 classifies weighing applications into **accuracy classes** I, II, III, III L, and IIII in descending order of **accuracy** requirements. Commercially available load cells are usually of class III or III L; retail and industrial applications generally fall into class III, while vehicle, railroad track, and hopper scales fall into class III L. Load cells are further classified by the **maximum number of load cell verification intervals** for which they are suitable, and as being suitable for single or multiple load cell applications. The tolerances applied to “multiple” cells are looser because of the partial cancellation that can be expected when two or more cells with normally distributed errors are summed. The classification for a load cell is often presented in an abbreviated fashion where the **maximum number of load cell verification intervals** is stated in units of 1,000, and “single” and “multiple” are abbreviated to S and M respectively. Thus, the classification for a cell could be stated as class III L 6 M (load cell suitable for class III L applications with a maximum of 6,000 divisions, and employing multiple cells). In the USA there is a National Type Evaluation Program (NTEP) which tests scales and load cells for compliance with the provisions of Handbook 44, and issues a Certificate of Conformance normally referred to as an NTEP certificate. The majority of states in the USA require scales used in **LFT** applications to have an NTEP certificate before installation.

4.1.2. The Organisation Internationale De Metrologie Legale (OIML) is an internationally recognized organization that publishes recommendations for various types of weighing equipment. These recommendations have been adopted in whole or in part by the Weights and Measures jurisdictions of many countries around the world. For load cells the recommendation document is

OIML R 60, Metrological Regulation for Load Cells. This document classifies load cells into **accuracy classes** A, B, C, and D, where class C corresponds approximately with Handbook 44's class III applications. Class C also encompasses Handbook 44's class III L applications since a separate class for these is not recognized. OIML R 60 does not distinguish between cells for single and multiple applications. A typical R 60 classification for a load cell is, for example C3, where the “3” refers to the **maximum number of load cell verification intervals** in units of 1,000. Various testing agencies are authorized to test load cells against the requirements of R 60 and issue OIML certificates of conformance.

4.1.3 Because the application of a load cell is not necessarily known in advance, there is a need to also specify the **minimum verification interval** referred to as V_{min} or v_{min} . V_{min} is the term used to define the smallest interval into which the load cell measuring range can be divided. This value is important as it is used to determine the smallest increment size a scale may have when using this load cell.

4.2. The availability of widely used standards has led to the presentation of performance specifications in a much abbreviated fashion, for example, by saying that a load cell is a 5,000 division class III multiple cell with a **$V_{min} = 0.5lb$** . Unfortunately this is not very meaningful to those who are not familiar with these standards, and makes it difficult to compare to specifications for non **LFT** load cells. Appendix I provides guidelines for the comparison of some of the more important specifications load cells.

4.3. Section 5 of the document Standard Load Cell Specifications provides a list of specifications and corresponding units of measurement that manufacturers are recommended to provide with each load cell, in sales brochures, and on detailed specification sheets.

5. Test Procedures

5.1 Scope

5.1.1. This section of the guideline provides general-purpose test procedures for qualifying load cells to a known **accuracy** for the measurement of weight and force.

5.1.2. Effort has been made to use terminology accepted within the scale and force measurement industries.

5.1.3. These test procedures apply as broadly as possible to all load cells as an aid to the end user. They are strictly for the benefit of the end user to gain useful knowledge in the use and application of load cells and

are by no means to be interpreted as being required of the end user.

5.1.4. For **legal for trade** weighing applications, specific type evaluation documents have been set up by Weights and Measures authorities, the two best known being NCWM Publication 14 and OIML R 60 (References 4 & 5). While many of the same basic principles apply, these SMA procedures are not meant to substitute for Weights and Measures procedures and tolerances.

5.1.5. These procedures pertain to load cells only. No attempt has been made to cover testing of complete systems using load cells as components.

5.2. Purpose

The specific objectives of this section are:

5.2.1. To provide the end user a good understanding of load cell test procedures that can be used for quantitative determination of critical load cell performance characteristics. The procedures are meant to provide for determining several performance characteristics from a single test, thus minimizing the number of procedures.

5.2.2. Establishment of an understanding of the **accuracy** of the most commonly used force generating means.

5.2.3. Encouragement of careful consideration of test conditions and environments under which evaluations are performed.

5.3. Environmental and Test Conditions

Before adequate qualification or **error** assessment of load cells or force transducers can be performed, careful attention must be given to environmental and test conditions. Significant discrepancies between users and manufacturers can result from inattention to such details. In light of this the following should be thoroughly considered:

5.3.1. Acceleration of Gravity – It is known that the acceleration of gravity varies by as much as 0.55% over the surface of the earth. The standard acceleration of gravity to which NIST normalizes, is 9.806650 m/sec². Most errors are expressed as a percentage of rated, applied, or full load so that absolute knowledge of the local acceleration due to gravity is not necessary.

5.3.2. **Standard Test Conditions** – Tests should be performed under recommended **standard test conditions**. If the **ambient conditions** (temperature, temperature gradients, humidity) differ from these, the effects on resulting data should be considered and

appropriate modifications to the actual test conditions made.

5.3.3. Loading, Compression Load Cell – Particular attention should be paid to the condition of the loading surface regardless of the loading means. Base plates on which the load cell rests should provide a flat, smooth surface free from rust, scratches or any foreign material. The load cell base should be inspected for the same conditions. Base plates of mild steel are recommended although it is well to abide by the recommendations of the manufacturer where such recommendations are made. Generally, the upper portion of the load cell is provided with a hardened convex surface. If other than a convex loading surface is provided, a load adapter must be used. The abutting bearing surface should have a hardness rating in accordance with the manufacturer's recommendation.

5.3.4. Loading, Tension Load Cell – To insure **axial loading** and to prevent **adverse loading conditions**, suitable flexures or equivalents should be used on each end of the load cell. Manufacturers' recommendations should be followed.

5.3.5. Loading, Beam Load Cell – Many load cells used in industry are bending or shear beam types. Once again, mount these on flat, smooth surfaces free from rust, scratches or any foreign material. Use the manufacturer's recommended torque and grade, for each threaded fastener.

To ensure **axial loading** and to prevent **adverse loading conditions**, suitable means of load introduction should be used. Manufacturer's recommendations should be followed.

5.3.6. Angularity, Concentricity and Orientation – Steps must be taken to insure that loads are applied concentric with and parallel to the **primary axis** of the load cell. Orient the load cell such that the effects of any known **angular** or **eccentric** loads will be minimized.

5.3.6.1. With any type of loading, alignment is critical. Misalignment between a rigidly mounted reference load cell, in a universal test machine for example, and a load cell under test, can induce **adverse loading conditions**. **Error** can result in the reference load cell and/or the load cell under test. Various types of load transmission devices are shown in WELMEC 2.4, Guide for Load Cells (Reference 2), with the purpose of reducing the effects of slight misalignment. Even with such devices, every effort must be made to insure proper alignment.

5.3.6.2. An angled base or a deflecting (non-rigid) load transmission structure, bridging 2 or more load cells, can cause **angular loading**. Rigidity in both the structure that the load cell mounts upon and the load application

structure, in addition to concepts mentioned in 5.3.6, are beneficial.

5.3.6.3. Some manufacturers quantitatively list **sensitivity** to extraneous loads in their specification sheets. (See Section 8 of this SMA document.) Additional information can be found in an Institute of Measurement and Control document (Reference 3).

5.3.7. **Reference Standard** - When a reference load cell is used, periodic verification of the standard's condition and calibration should be made.

5.3.7.1. It is important to note that the uncertainty of one's **reference standard** for force generation or calibrated weights is critical to know. The **reference standard** should be at least 4 times better than the **accuracy** being sought in the load cell under test.

5.3.8. **Electrical Stabilization** – Allow a powered up **warm up period** for the load cell under test, the excitation supply, and the readout instrumentation, as recommended by the various manufacturers of the equipment used.

5.3.9. **Temperature Stabilization** – When temperature effect tests are being performed, allow a sufficient time for temperature stabilization of both the load cell and adjacent load apparatus. Monitor one or more points on the load cell as well as **ambient temperature**. Large load cells require longer soak times, typically 3 hours after the outside of the load cell is found to be within 2.2°C of the final target temperature. Thermocouples on the surface of a load cell should be potted or taped down within a small reservoir of thermal transfer compound.

5.3.9.1. Particular attention should be paid to minimize conductive loss through the envelope of temperature control by way of connecting apparatus (rods, cables, plates, etc.) or poor insulation. These losses can cause temperature gradients through the load cell, resulting in **error** or instability. Plan for ample space around the load cell so that immediate connecting means are at the target temperature as well. When using a load plate, mount the plate on insulating material or on standoffs that minimize conductive area.

5.3.10. **Barometric Pressure Effects** - Where changes in barometric pressure may significantly affect zero balance, such changes should be considered.

5.3.11. **Load Stability** – A loading means should be used which will provide test loads sufficiently stable to permit readings within the precision required.

5.3.12. **Operator Capability** – Accepted laboratory techniques should be used by qualified operators, a good understanding of metrology being necessary.

5.4. Load Generating Systems

The **accuracy** of test results obtained through any load test procedure is no better than the loading means, instrumentation, and operator skill and knowledge. The combined overall **accuracy** of the loading means and instrumentation should be at least three times that desired for the performance characteristics being measured. There are many loading devices available for load cell evaluation with various degrees of **accuracy**, each usually compared to some reference mass.

5.4.1. **Dead Weights** – The most accurate means for generating forces is provided by the use of calibrated dead weights, supported by the load cell under test. The known **accuracy** of the test weights should be at least 4 times better than the **accuracy** of the load cell under test.

5.4.1.1. **Dead Weight Testing Machines** – Dead weight testing machines are used with weights standardized by the National Institute of Standards and Technology and other organizations.

5.4.1.2. **Mechanical or Hydraulic Loading and Reference Standard** – A frequently used method of generating force is through the use of mechanical screws or hydraulic presses. The load cell under test is loaded in series with a **reference standard**, usually a traceable load cell. In so doing, the applied load is measured by **the reference standard** and is therefore known to the **accuracy** with which the **reference standard** has been calibrated. A comparison of the output of the **reference standard** and the load cell under test provides a measurement of various performance characteristics of the test cell.

5.4.1.3. **Dead Weight Multiplying** – Forces greater than those provided by pure dead weight loading can be generated through the use of dead weights and lever multiplying systems.

5.5. Instrumentation

5.5.1. There are many forms of instrumentation devices available to the user and manufacturer, too many to cover adequately in this guideline. Instrumentation should be chosen with an **accuracy** at least 4 times better than that desired in the evaluation to be made. It is typical that the displayed resolution of the instrument be 10 times the accuracy of interest.

5.5.2. **Power Supply / Excitation Voltage** – Use power supplies with adequate stability and of a magnitude recommended by the manufacturer.

5.6. Overall System Accuracy

5.6.1. The overall **accuracy** of the force generating means and readout instrumentation combined should be at least 3 times better than that desired of the load cell under test.

5.6.2. For **legal for trade** applications, this one-third error in the “test process” (reference 4) applies for each tolerance step. Once again, for **legal for trade** applications, use the appropriate documents, references 4 and 5.

5.7. Test Procedures

Generally, the performance characteristics of a load cell are assessed by the following parameters:

- **NON-LINEARITY**
- **HYSTERESIS**
- **NON-REPEATABILITY**
- **TEMPERATURE EFFECT ON RATED OUTPUT**
- **TEMPERATURE EFFECT ON ZERO LOAD OUTPUT**
- **CREEP & MINIMUM DEAD LOAD OUTPUT RETURN**

Tests are designed to provide a quantitative determination of each characteristic.

The load cell's **zero load output** will likely read some value slightly off true zero, though within the manufacturer's **zero balance** specification. Dead load of test apparatus (hooks, pans, platforms, etc.) will add to this offset. This value is subtracted to obtain a span value or the **temperature effect on zero load output**, for a couple of examples.

It should never be necessary to zero a readout device during any of the tests. Valuable data can be lost this way. Manipulation of values to remove zero-load readings are generally performed during results analysis.

5.7.1. Test Procedure for determination of:

- **NON-LINEARITY**
- **HYSTERESIS**

5.7.1.1. Refer to Environmental and Test Conditions (section 5.3) to ensure that proper consideration has been given to those items prior to performing the following tests. Should temperature effect determinations (section 5.7.2) be made later, standard temperature should here be considered as $20^{\circ}\text{C} \pm 2^{\circ}\text{C}$.

5.7.1.2. Insert the load cell into the force generating system and exercise by applying **maximum load (D_{\max})** three times, returning to **minimum load (D_{\min})** after each load application.

5.7.1.3. Wait for the output to stabilize, not exceeding 5 minutes.

5.7.1.4. Measure the initial output.

5.7.1.5. Apply ascending loads in increments to D_{\max} . Take readings after a short **stabilization period** for each load increment without overshooting each intended load. Four or five load points are sufficient. It is common to apply test loads just under the load value where the tolerance value will increase.

5.7.1.6. Remove the same test loads in a descending manner, taking readings upon reaching each stabilized load.

5.7.1.7. Upon removal of the last test load, record the output at D_{\min} .

5.7.1.8. Repeat 5.7.1.4. through 5.7.1.7. two more times.

5.7.1.9. With the average readings from 3 runs, **non-linearity** and **hysteresis** can be determined as illustrated in Figures 13, and 14.

5.7.2. Test Procedure for determination of:

- **TEMPERATURE EFFECT ON MINIMUM DEAD LOAD OUTPUT**
- **TEMPERATURE EFFECT ON RATED OUTPUT**

5.7.2.1. Perform this test following the previous test (section 5.7.1.), without zeroing the readout device.

5.7.2.2. Change to the “cold” temperature at the low end of the manufacturer's recommended operating range, or at the low end of intended use, or at a temperature of special interest. For a load cell intended for outdoor uses, a temperature of -10°C is considered adequate.

5.7.2.3. Exercise the load cell to D_{\max} three times, returning to D_{\min} after each load application.

5.7.2.4. Wait for the output to stabilize, not exceeding 5 minutes.

5.7.2.5. Perform the sequence outlined in steps 5.7.1.4. through 5.7.1.7. three times.

5.7.2.6. Change to the “hot” temperature at the high end of the manufacturer's recommended operating range, or at the high end of intended use, or at a temperature of special interest. For a load cell intended for outdoor uses, a temperature of 40°C is considered adequate.

5.7.2.7. Exercise the load cell to D_{\max} three times, returning to D_{\min} after each load application.

5.7.2.8. Wait for the output to stabilize, not exceeding 5 minutes.

5.7.2.9. Perform the sequence outlined in steps 5.7.1.4. through 5.7.1.7. three times.

5.7.2.10. Return to the standard test temperature used in 5.7.1. and exercise as before.

5.7.2.11. After stabilization of the output, not exceeding 5 minutes, repeat steps 5.7.1.4. through 5.7.1.7.

5.7.2.12. For each temperature, average the readings from 3 runs for determination of **load cell error**, which can be graphed as shown in Figure 15. The zero error line passes through both the average output at D_{min} and the average room temperature on-loading output at 75% of $D_{max} - D_{min}$.

5.7.2.13. The following expressions provide for the determination of **temperature effect on minimum dead load** and **rated output**:

TEMPERATURE EFFECT ON MINIMUM DEAD LOAD OUTPUT =

$$\frac{Z_2 - Z_1}{(T_2 - T_1)} \times \frac{100\% \text{ of Rated Output}}{\theta} \text{ } ^\circ\text{C}$$

TEMPERATURE EFFECT ON RATED OUTPUT =

$$\frac{S_2 - S_1}{(T_2 - T_1)} \times \frac{100\%}{S_R} \text{ } ^\circ\text{C}$$

Where:

Z_1 Z_2 = **Zero balance** (or **minimum dead load**) readings at specific temperatures

T_1 T_2 = Corresponding specific temperatures

θ = Rated output

S_R = Span at room (standard) temperature

S_1 S_2 = Span at the specific temperatures for the load applied

Notes: The 100 multiplier is used to express characteristics in terms of percent per °C.

In the event there is no test load equivalent to rated load, employ a test load which is as close to rated load as possible for determination of S_R , S_1 , and S_2 .

5.7.3. Determination of:

- **NON-REPEATABILITY**

5.7.3.1. Test data from Sections 5.7.1. and 5.7.2. is used to determine **non-repeatability**.

5.7.3.2. For each set of the three data points, taken at the same temperature, **non-repeatability** is the maximum deviation between any two.

5.7.4. Test Procedure for determination of:

- **CREEP**
- **MINIMUM LOAD OUTPUT RETURN**

5.7.4.1. Refer to Environmental and Test Conditions, Section 5.3., to insure that proper consideration has been given to those items prior to performing the following test.

5.7.4.2. Insert the load cell into the force generating system and exercise by applying a load equal to the **creep** test load at least three times, returning to **minimum load** after each load application. The **minimum load** of test should be equal to or, if necessary for practical reasons, slightly higher than the **minimum dead load** of the load cell.

5.7.4.3. Wait a period of ½ to 1 hour.

5.7.4.4. Measure the **minimum load signal**.

5.7.4.5. Apply the **creep** test load (preferably dead weights). This should be a force that is 90 to 100 percent of the load cell capacity. Apply the load as quickly as possible. Take the first reading (θ_2 in Figure 16) after a short stabilization period.

5.7.4.6. Periodically read the output at recorded time intervals over the period of interest. A 30 minute period is normally useful toward evaluating **creep**.

5.7.4.7. Remove the test load as rapidly as possible. Record **minimum load signal** after a short stabilization period.

5.7.4.8. For non-static force generating systems, only **minimum load output** return can be determined. Meaning that if the load applied is not stable a creep reading cannot be reliably determined, however a **minimum load output** return can still be determined.

5.7.4.9. With the foregoing procedure the above performance characteristics can be determined in accordance with the curves and expressions illustrated in Figure 16.

5.7.5. Test Procedure for determination of the effects of:

- **ANGULAR LOAD, CONCENTRIC**
- **ANGULAR LOAD, ECCENTRIC**
- **ECCENTRIC LOAD**
- **SIDE LOAD**

5.7.5.1. Refer to Environmental and Test Conditions, Section 5.3., to insure that proper consideration has been given to those items prior to performing the following test:

5.7.5.2. Insert the load cell into the force generating system and exercise by applying **rated capacity** at least three times, returning to **minimum load** or zero load after each load application.

5.7.5.3. For determination of the effects of **concentric angular loading** and **side loading**, insert wedge blocks above and below the load cell as illustrated in Figure 17a. The angle B, subtended by the two larger surface areas of each block, should be equivalent to the angle of interest and should result in the **side load** of interest.

5.7.5.4. Measure **zero load output** with the wedge blocks in place.

5.7.5.5. Apply **rated capacity** (L) and read the output as soon as the load has stabilized.

5.7.5.6. Remove the load and record the **zero load output** after output has stabilized.

5.7.5.7. **Side load** caused by angular loading is calculated as the load multiplied by the sine of the angle between the load and the **primary axis** of the load cell (Figure 17a):

$$L_s = L \sin B$$

The **primary axis** of the load cell sees only the cosine function of the applied force:

$$L_a = L \cos B$$

5.7.5.8. For determination of the effects of **eccentric angular loading**, remove the upper wedge block (Figure 17b) and repeat steps 5.7.5.4. through 5.7.5.6. If eccentricities other than that obtained in the foregoing are desired, a flat load button should be used and the amount of eccentricity adjusted through placement of the load cell.

5.7.5.9. For determination of the effects of **eccentric loading**, remove the lower wedge block, use a flat load button, and adjust eccentricity through placement of the load cell (Figure 17c). Repeat steps 5.7.5.4. through 5.7.5.6.

5.7.5.10. For depiction of the concepts of **angular** and **eccentric loading** and equations for the calculation of **errors**, see Figure 17.

5.7.6. Test Procedure for determination of:

- **BAROMETRIC PRESSURE EFFECT ON ZERO LOAD OUTPUT**

5.7.6.1. Refer to Environmental and Test Conditions, Section 5.3., to insure that proper consideration has been given to those items prior to performing the following test.

5.7.6.2. At room temperature and **minimum dead load**, insert load cell into a pressure chamber.

5.7.6.3. Monitor no-load **signal** until stable and record the **minimum dead load output**.

5.7.6.4. Change chamber pressure a specified amount lower or higher than atmospheric pressure and record the **minimum dead load output**.

5.7.6.5. The above performance characteristics can be determined in accordance with the following expression:

BAROMETRIC PRESSURE EFFECT ON ZERO LOAD OUTPUT =

$$\frac{Z_1 - Z_2}{(P_1 - P_2) \theta} \times \frac{100 \% \text{ of Rated Output}}{\text{Unit of Pressure}}$$

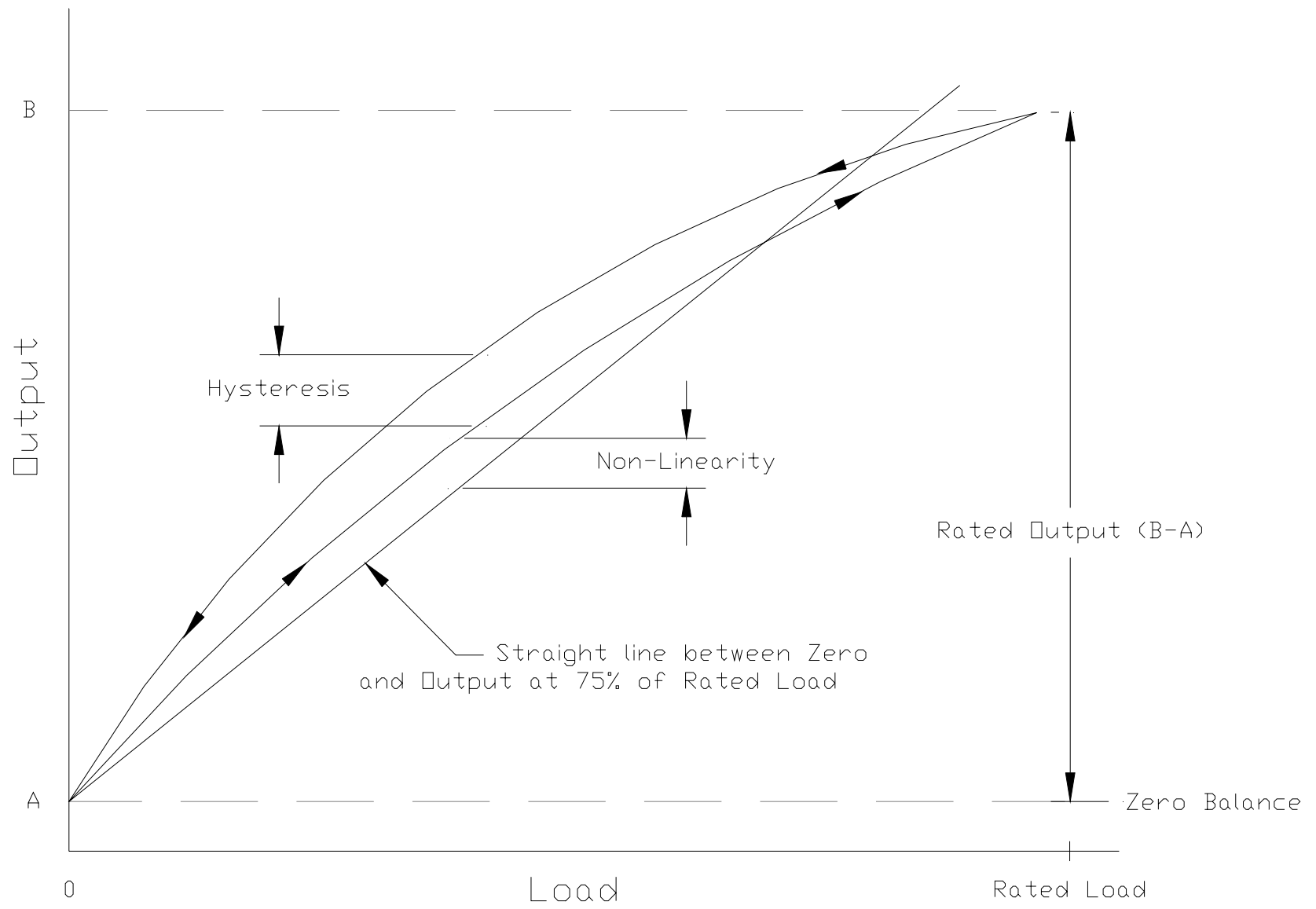

Figure 13: Load cell calibration curve

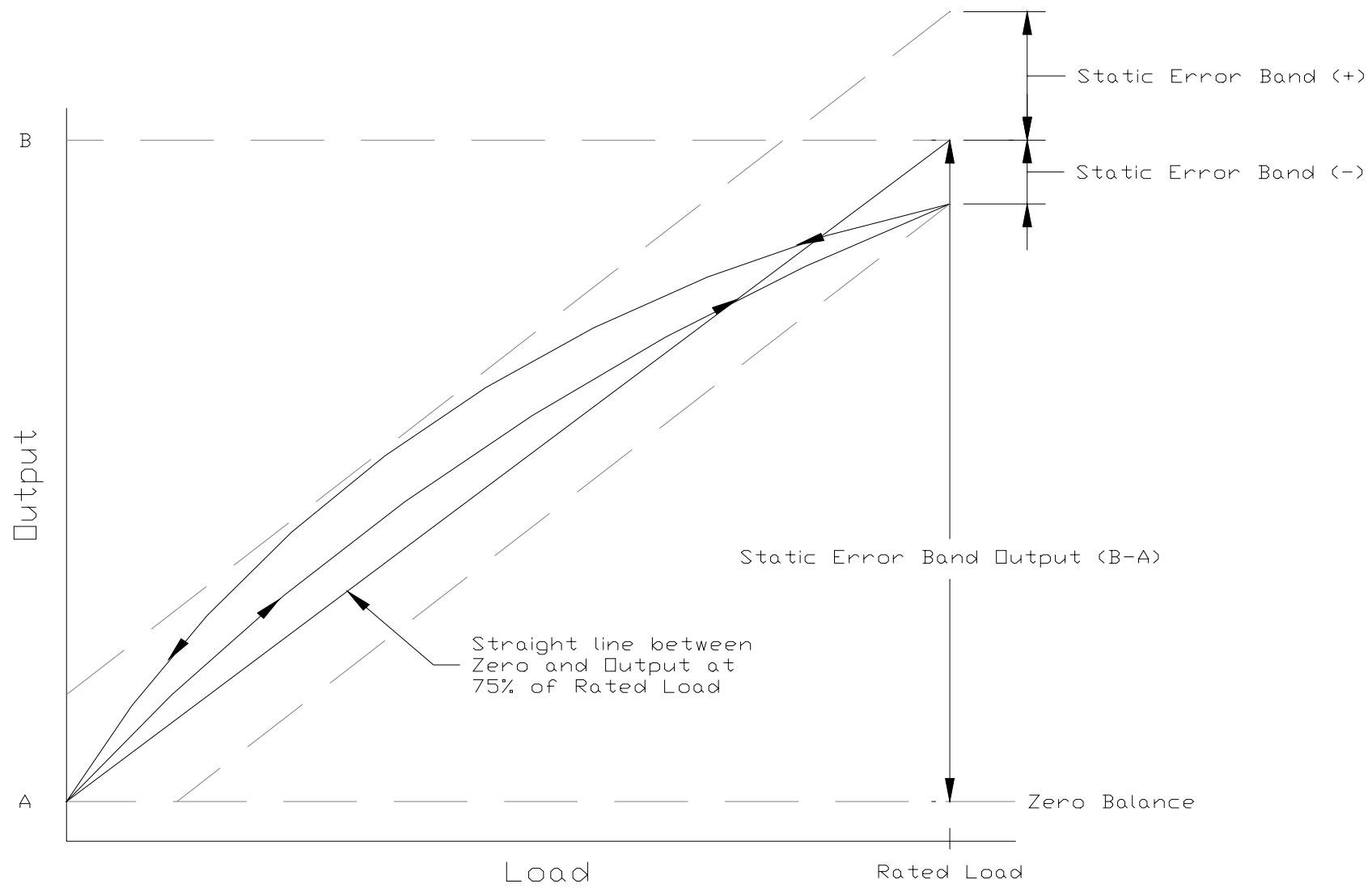

Figure 14: Load cell calibration curve, static error band

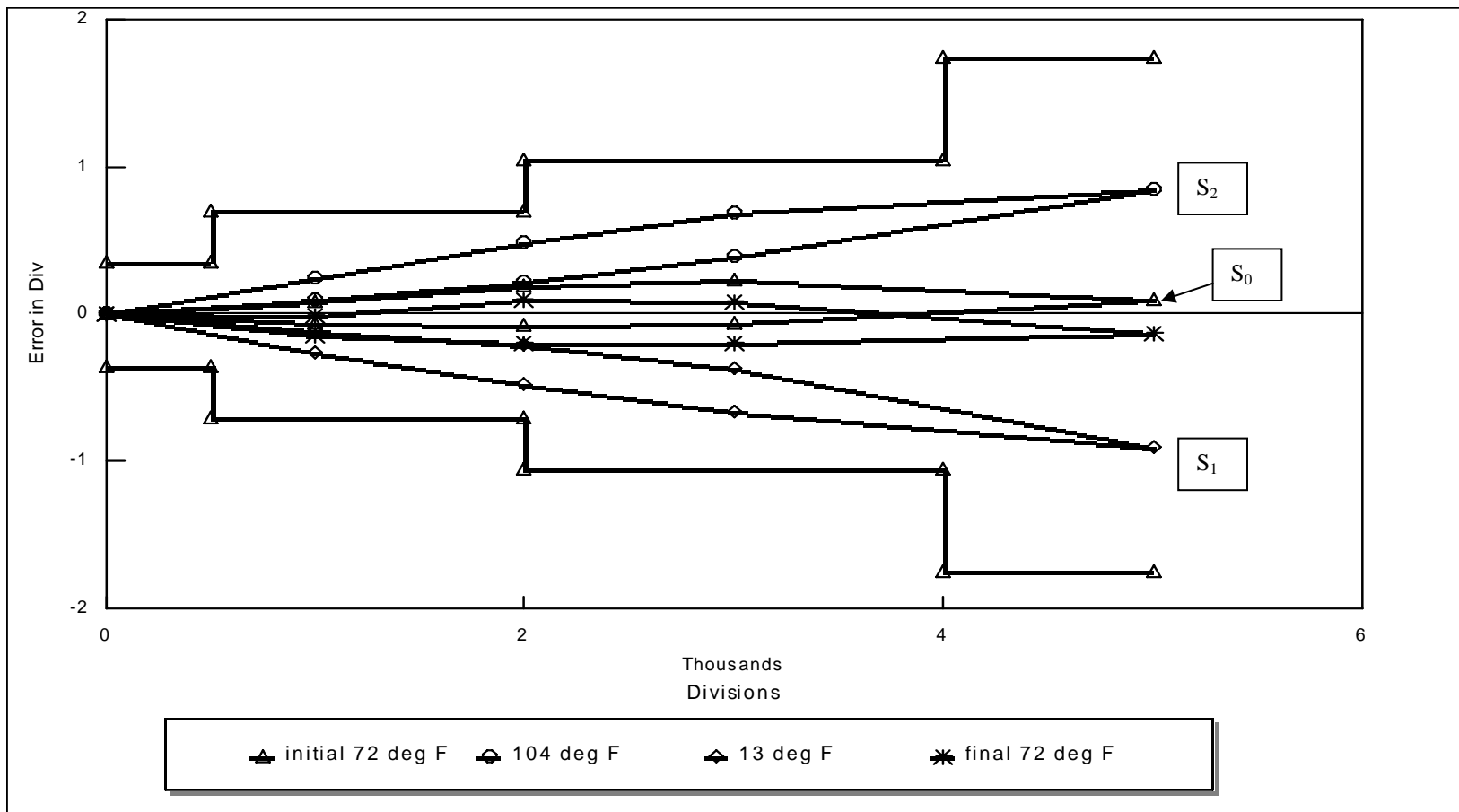

Figure 15: Calibration curve for load cell error vs. load, with NTEP 5000 division tolerance band shown. The load axes are shown in number of divisions. Each division represents the quantity $(D_{\max} - D_{\min}) / 5000$ in this case. One can see the error in span caused by shifted temperature. Each load sequence is normalized to zero error at zero divisions.

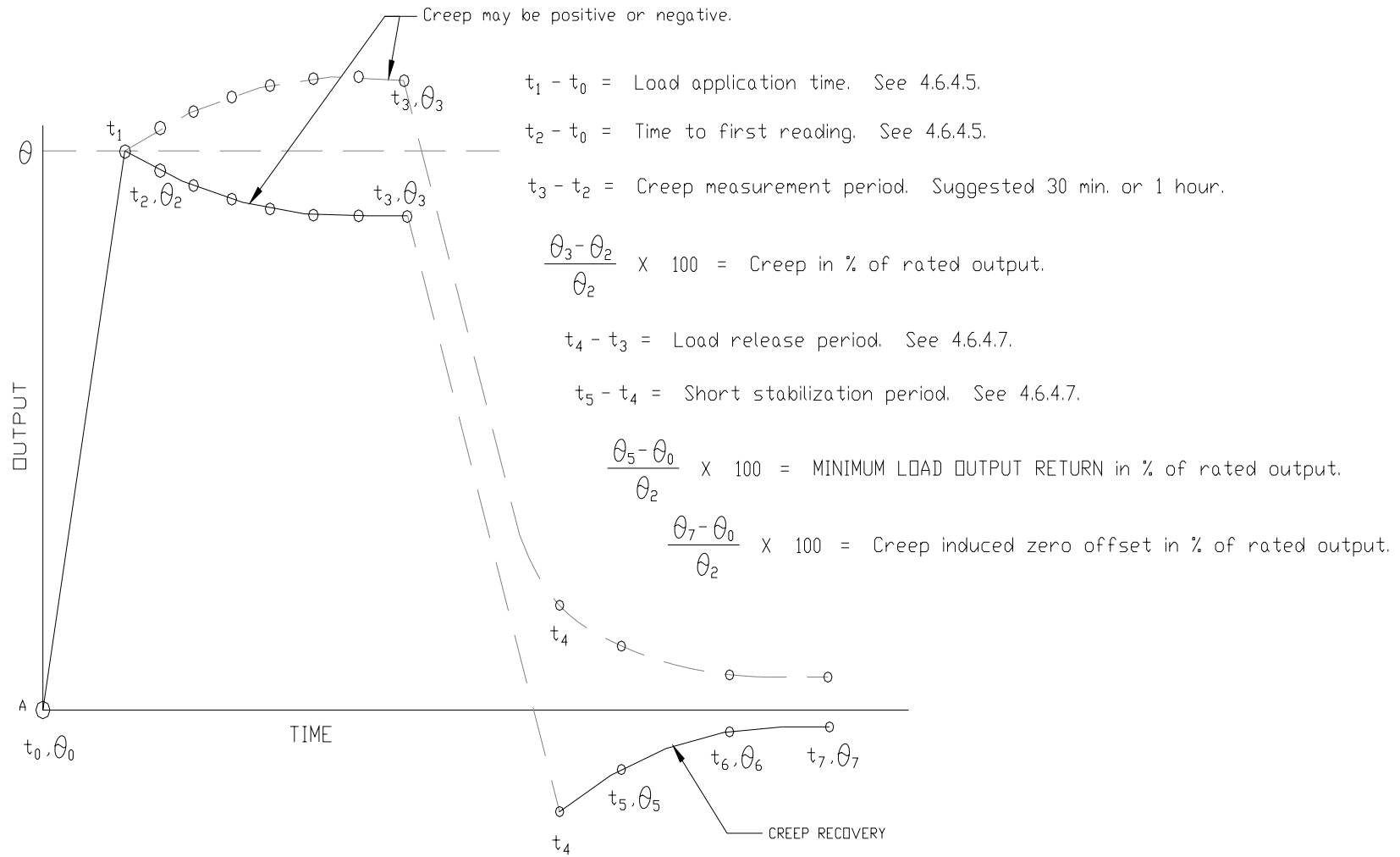
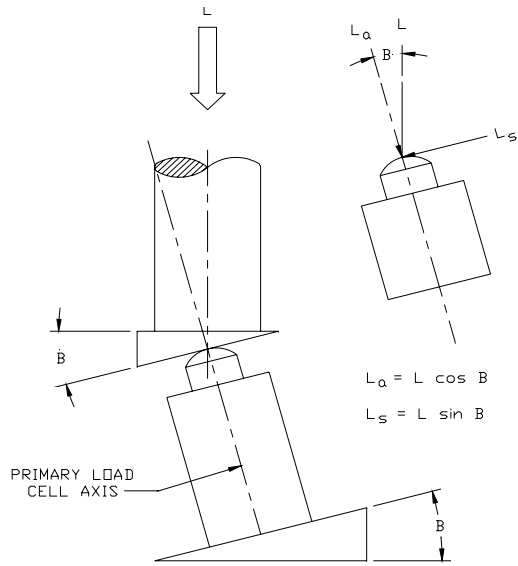

Figure 16: Load cell creep and minimum dead load output return

Figure 17a
CONCENTRIC ANGULAR
LOADING
AND SIDE LOADING



$$\text{Error} = \frac{\theta_0 - \theta_1 / \cos B}{\theta_0} \times 100$$

Figure 17b
ECCENTRIC ANGULAR
LOADING

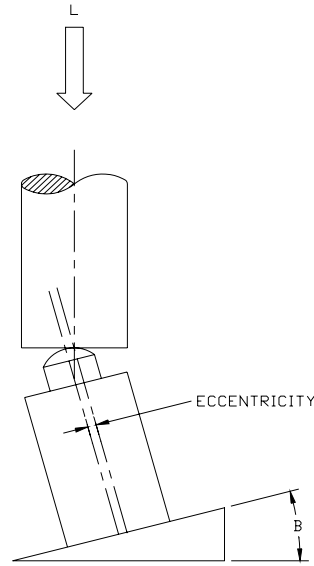

$$\text{Error} = \frac{\theta_0 - \theta_2 / \cos B}{\theta_0} \times 100$$

Figure 17c
ECCENTRIC LOADING

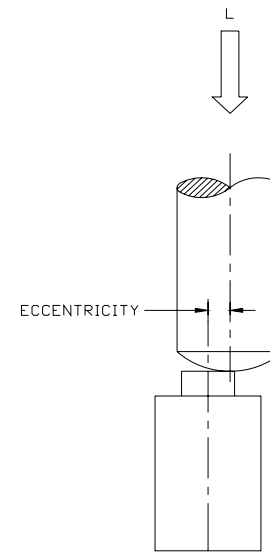

$$\text{Error} = \frac{\theta_0 - \theta_3}{\theta_0} \times 100$$

Where:

θ_0 = Output at level axial loading of magnitude L
 $\theta_1, \theta_2, \theta_3$ = Output under any unfavorable loading conditions at load L

L = Load of test, preferably rated load or close to it.
 L_a = Axial Load
 L_s = Side Load
 B = Angle

Figures 17, 17a, 17b and 17c: Load cell errors due to angular, eccentric, and side loads. All errors are shown in percent of rated output.

Appendix I

Comparison of Load Cell Specifications

Appendix I - Comparison of Load cell specifications

This section will consider three important performance specifications, **creep**, **temperature effect on zero load output**, and **combined error**, and provide a basis for comparison of the various specifications provided within the industry. Note that load cell manufacturers generally specify a compensated temperature range over which the specifications for temperature effects are valid. Handbook 44 and OIML R60 specify a “standard” temperature range of -10 to +40°C; if other than this, the temperature range must be marked on the cell or in an accompanying document.

1. Creep and Minimum Dead Load Output Return

1.1. For non **LFT** load cells **creep** data is usually provided for a test where the cell’s **rated capacity (R.C.)** has been applied for 20 minutes at room temperature, and the **creep** is expressed as a percentage of **R.C.** Handbook 44 and OIML R.60 also have **creep** return requirements. OIML R 60 refers to this requirement as **minimum dead load output return** where Handbook 44 refers to this requirement as **creep recovery**. This requirement is typically not specified for non **LFT** load cells.

1.2. For **LFT** load cells refer to Handbook 44 and OIML R 60 for **creep** specifications of various load cell **accuracy classes**. Tests are performed at three temperatures (room temperature and the upper and lower temperature extremes as defined by the manufacturer). Handbook 44 and OIML R 60 also have **creep** return requirements. OIML R 60 refers to this requirement as **minimum dead load output return** where Handbook 44 refers to this requirement as **creep recovery**

2. Temperature effect on Zero load output

2.1. For non **LFT** load cells the **temperature effect on zero load output** is generally expressed as a percentage of **R.C.** per °C.

2.2. For **LFT** cells **temperature effect on zero load output** is often provided in terms of V_{min} , which can be stated in units of mass, or as a fraction or percentage of **rated capacity**. To convert V_{min} (stated in units of mass) to %**R.C./°C** do the following:

For all Handbook 44 class III S and M, and all R 60 class B, C, & D cells:

$$\text{Temperature effect on zero load output} = 14V_{min}/R.C. (\%R.C./^{\circ}C)$$

For all Handbook 44 class III L cells:

$$\text{Temperature effect on zero load output} = 42V_{min}/R.C. (\%R.C./^{\circ}C)$$

3. Combined Error

3.1. When weight is applied incrementally to a load cell up to **its rated capacity** and then removed again, a **calibration curve** similar to that in Figure 13 can be plotted. A **calibration curve** shows applied load on one axis, and **load cell output** on the other. The **calibration curve** for an ideal load cell would be a straight line with no difference between loading and unloading cycles. Because of **non-linearity** and **hysteresis**, the typical **calibration curve** has the characteristic shape shown in Figure 13 where the arrows indicate the path traversed during loading and unloading cycles.

3.1.1. For **LFT** cells this data is usually presented as shown in Figure 15 where only the **errors** are plotted against applied load; in this case the ideal load cell’s **calibration curve** would be a single line along the applied load axis, the loading and unloading curves being indistinguishable. There are three curves shown in Figure 15, these are the **calibration curves** at the temperatures indicated. Figure 15 graphically represents the errors due to **non-linearity**, **hysteresis**, and **temperature effect on rated output**. Handbook 44 and OIML R60 do not apply tolerances to these individual errors, but instead apply a single stepped tolerance that applies to the **combined error** due to **non linearity**, **hysteresis**, and **temperature effect on rated output**. This stepped tolerance is shown in Figure 15 individually, **the non-linearity, hysteresis, and temperature effect on rated output** can have any value, as long as the **calibration curves** remain within the stepped tolerance “tunnel” at all points.

3.1.2. For non **LFT** cells a **combined error** is sometimes provided, stated as a percentage of **R.C.** This is a straight line tolerance from zero to **rated capacity**. More typically, individual specifications for **non-linearity**, **hysteresis**, and **temperature effect on rated output** are provided for non **LFT** load cells. An approximate comparison to the error tunnel for a **LFT** cell can be made by graphical means. First draw the **calibration curve** for room temperature by assuming that the maximum error due to **non-linearity** and **hysteresis** occur at 50% **R.C.** and that they are additive. Then displace the **R.C.** point of the **calibration curve** (hinging the zero point at zero) in both the positive and negative direction by an amount corresponding to the **temperature effect on rated output** specification for the cell. Now plot the error tunnel for the appropriate **LFT** cell from the information in Handbook 44 or OIML R 60.

Appendix II

Load Cell Functional Testing

Appendix II - Load Cell Functional Testing

When assessing the functionality of a **strain gauge load cell**, measurement of the following parameters is most helpful.

1. **Zero Offset – With recommended excitation voltage** supplied, a **zero load output** greater than the manufacturer's specification is a good indication that the load cell may have been damaged. This is most often a case of overloading and may be either positive or negative. It could also be the result of moisture damage.
2. **Zero Instability** – An unstable **zero load output** is an indication of leakage current being drained from the **load cell circuit**, most often the result of moisture damage. This instability will likely be superimposed on the **rated output** as well.
3. **Terminal Resistances** – With the many load cells available on the market, **load cell circuit** resistances can vary. Though there is no "correct" value for a manufacturer to use, some of the more common are 350 Ω , 700 Ω , 900 Ω , and 1000 Ω . When checking the excitation, you can expect the resistance to be somewhat higher than the internal **Wheatstone bridge**, due to the addition of **compensation** networks.

The modulus (spring rate) of load cell spring elements drops with temperature, producing higher outputs as temperature increases. Additionally, most strain gauges used in load cells have gauge factors that increase with temperature. These effects are then attenuated with temperature sensitive resistors and shunts.

Temperature sensors and software correction algorithms on circuitry mounted in the casing of the load cell are another way to compensate for increasing output.

When modulus compensating nickel-chromium (Karma) foil is used to make strain gages, excitation lead readings can then be close to nominal, 350 Ω for example, or slightly higher.

For proper **terminal resistance** readings between all combinations of excitation and signal wires of a load cell, use the manufacturer's specifications.

4. **Insulation Resistance – Insulation resistance** is a good indication of the integrity of a load cell. Low **insulation resistance** can cause instability due to leakage current from the **load cell circuit** to the base material of the load cell. Unstable readings and **non-repeatability** problems when measuring **rated output** can be indications of low **insulation resistance**. To measure **insulation resistance**, an ohmmeter with measuring capability in the range of giga-ohms is necessary. When new, the resistance between any direct bridge lead and the base metal of the load cell should be 2000 mega-ohms or higher. Load cells may operate accurately with **insulation resistance** down in the range of 500 mega-ohms, however instability can begin even before such a low value occurs.

It is recommended that an ohmmeter be used which does not apply more than 50 volts to the circuitry under test.

Section 4 of the document Standard Load Cell Specifications, labeled Construction and Protection (CP) Code, gives insight into steps that load cell manufacturers take to insure that water, a common cause of instability and failure, is kept away from the sensitive strain measuring elements of the load cell.

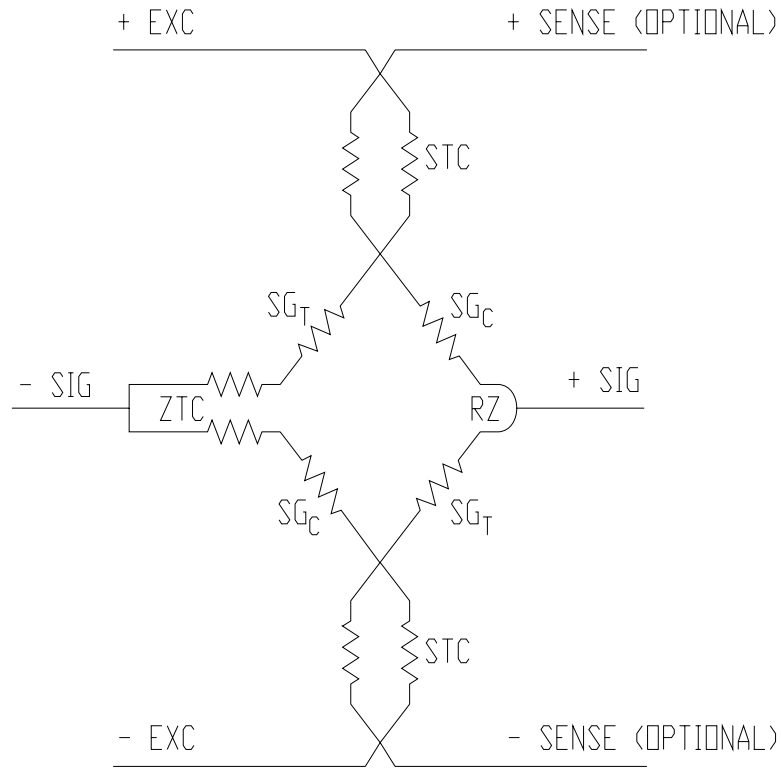

Figure 18: A typical strain gauge bridge circuit

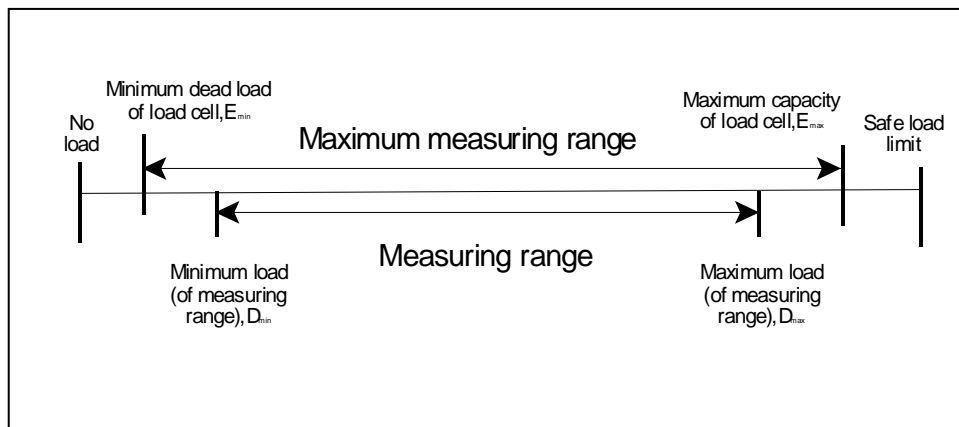

Figure 19: Illustration of certain definitions: NOTE: The terms that appear above the center horizontal line are parameters that are fixed by the design of the load cell. The terms that appear below that line are parameters that are variable, dependent on the conditions of use or in the test of a load cell (in particular, those load cells used in weighing instruments).

Appendix III

Load Cell Terminology

Appendix III - Load Cell Terminology

ACCURACY: The deviation of a result from the actual applied load as a ratio to that applied load.

ACCURACY CLASS: A class of LOAD CELLS that are subject to the same levels of performance.

ADVERSE LOADING CONDITIONS: Undesirable physical factors that result in applied MOMENT LOADS, ANGULAR LOADS, SIDE LOADS or other extraneous inputs.

AMBIENT CONDITIONS: The conditions (humidity, pressure, temperature, etc.) of the medium surrounding the LOAD CELL.

AMBIENT TEMPERATURE: The temperature of the medium surrounding the LOAD CELL.

ANGULAR LOAD, CONCENTRIC: A load applied concentric with the PRIMARY AXIS at the point of load application and at some angle with respect to the PRIMARY AXIS.

ANGULAR LOAD, ECCENTRIC: A load applied eccentric to the PRIMARY AXIS at the point of load application and at some angle with respect to the PRIMARY AXIS.

AXIAL LOAD: A load applied along (parallel to and concentric with) the PRIMARY AXIS.

BAROMETRIC PRESSURE EFFECT ON ZERO LOAD OUTPUT: The change in ZERO LOAD OUTPUT due to a change in barometric pressure.

BRIDGE: See WHEATSTONE BRIDGE.

CALIBRATION CURVE: The characteristic curve of **load cell output** relative to true applied load.

COMBINED ERROR: (the combined effect of non-linearity, hysteresis and temperature effect on rated output) The maximum deviation from the straight line drawn between the zero load output and a point equal to 75% of rated output at standard test conditions and measured on both increasing and decreasing loads and at the extremes of the compensated temperature range. [expressed as a percentage of rated output]

COMPENSATION: The utilization of supplementary devices, materials, or processes to minimize known sources of error.

COMPRESSION: A compressive force applied to a load cell.

CREEP: The change in LOAD CELL SIGNAL occurring with time while under constant load and with all environmental conditions and other variables also remaining constant.

CREEP RECOVERY: See MINIMUM DEAD LOAD OUTPUT RETURN.

DEAD LOAD RETURN (DR): See MINIMUM DEAD LOAD OUTPUT RETURN.

DEFLECTION: The displacement along the PRIMARY AXIS of the LOAD CELL between no-load and RATED LOAD conditions.

ECCENTRIC LOAD: Any LOAD applied parallel to but not concentric with the PRIMARY AXIS.

ERROR: The algebraic difference between the indicated and the true value of the LOAD being measured.

EXCITATION VOLTAGE: The voltage applied and measured at the excitation terminals of the load cell. In six wire configuration the measurement is made using the SENSE leads. [Expressed in volts]

EXCITATION VOLTAGE, MAXIMUM: The maximum EXCITATION VOLTAGE at which the load cell can be continuously operated and meet the manufacturer's specifications. [Expressed in volts]

EXCITATION VOLTAGE, RECOMMENDED: The EXCITATION VOLTAGE at which the load cell has been tested during manufacture. [Expressed in volts]

FIXED END: The mounted end of a beam load cell that is statically attached to the non-moving element(s) of a system.

HYSTERESIS: The maximum difference between LOAD CELL OUTPUT readings for the same applied load; one reading obtained by increasing the load from zero and the other by decreasing the load from RATED LOAD. [Expressed in percent of RATED OUTPUT.]

INPUT RESISTANCE: The resistance of the electrical circuit of the load cell as measured at the input terminals, with the output terminals open. [Expressed in ohms]

INSULATION RESISTANCE: The DC resistance measured between the LOAD CELL CIRCUIT and the LOAD CELL structure. [Expressed in Mega-Ohms (megohms).]

Measured at fifty volts DC and under STANDARD TEST CONDITIONS.

LEGAL FOR TRADE (LFT): An application where the load cell or scale is used in the determination of charges for goods or services rendered. Sometimes referred to as a “commercial application”..

LFT: See LEGAL FOR TRADE

LIVE END: The unrestrained end of a beam load cell that is usually attached to the load receiving element(s) of a system.

LOAD: The weight or force applied to the LOAD CELL.

LOAD CELL: A force transducer that measures force or weight by converting the measured quantity (force or weight) into another measurable quantity (SIGNAL).

LOAD CELL CIRCUIT: The entire combination of electrical components used to create a load cell’s SIGNAL from the EXCITATION VOLTAGE.

LOAD CELL ERROR: The difference between the load cell measurement result and the true value of the applied load.

LOAD CELL MEASURING RANGE: The range of values of the measured quantity for which the result of measurement should not be affected by an error exceeding the maximum permissible error.

LOAD CELL OUTPUT: The signal derived from the load cell as an expression of the applied load.

LOAD CELL VERIFICATION INTERVAL (v): The load cell interval, expressed in units of mass, used in the test of the load cell for ACCURACY classification.

MAXIMUM CAPACITY (E_{max}): The largest value of a quantity that may be applied to a load cell without exceeding the maximum permissible error.

MAXIMUM LOAD (D_{max}): The largest value of a quantity that can be applied to a load cell during test or use. This value shall not be greater than E_{max}.

MAXIMUM LOAD, SAFE: See SAFE LOAD LIMIT.

MAXIMUM LOAD, ULTIMATE: See ULTIMATE LOAD LIMIT.

MAXIMUM NUMBER OF LOAD CELL VERIFICATION INTERVALS (n_{max}): The maximum number of load cell intervals into which the LOAD CELL MEASURING RANGE may be divided for which the result of measurement shall not be affected by an error exceeding the maximum permissible error (mpe).

MAXIMUM PERMISSIBLE ERROR (mpe): The extreme values of the permitted error for the combined effect of non-linearity, hysteresis, and temperature effect on rated output

over the specified compensated temperature range. [used in relation to legal for trade load cells and is stated in load cell verification intervals].

MINIMUM DEAD LOAD (E_{min}): The smallest value of a quantity that may be applied to a load cell without exceeding the maximum permissible error.

MINIMUM DEAD LOAD OUTPUT: The load cell SIGNAL at MINIMUM DEAD LOAD.

MINIMUM DEAD LOAD OUTPUT RETURN (DR): The difference in LOAD CELL OUTPUT at MINIMUM DEAD LOAD, measured before and after load application.

MINIMUM LOAD CELL VERIFICATION INTERVAL (v_{min}): The smallest LOAD CELL VERIFICATION INTERVAL into which the LOAD CELL MEASURING RANGE can be divided. [Expressed in units of the measured quantity or as a percentage of MAXIMUM CAPACITY (E_{max}.)].

MINIMUM LOAD (D_{min}): The smallest value of a quantity that is applied to a load cell during test or use. This value shall not be less than E_{min}.

NCWM: The National Conference on Weights and Measures

NIST: The National Institute of Standards and Technology

NON-LINEARITY: The maximum deviation of the CALIBRATION CURVE from a straight line drawn between the load cell SIGNAL at MINIMUM LOAD and 75% of the RATED CAPACITY. [Expressed as a percentage of the RATED OUTPUT and measured on increasing load only.]

NON-REPEATABILITY: The maximum difference between LOAD CELL SIGNAL at repeated loads under identical loading and environmental conditions, expressed as a percentage of the RATED OUTPUT.

NTEP: NATIONAL TYPE EVALUTION PROGRAM

NUMBER OF LOAD CELL VERIFICATION INTERVALS (n): The number of load cell intervals into which the LOAD CELL MEASURING RANGE is divided.

OIML: International Organization of Legal Metrology

OUTPUT RESISTANCE: The resistance of the electrical circuit of the load cell as measured at the output terminals, with the input terminals open circuit. [Expressed in ohms]

OVERLOAD, SAFE: See SAFE LOAD LIMIT.

OVERLOAD, ULTIMATE: See ULTIMATE LOAD LIMIT.

PRIMARY AXIS: The axis along which the LOAD CELL is designed to be loaded.

PATTERN EVALUATION: See TYPE APPROVAL.

RATED CAPACITY (R.C.): The MAXIMUM LOAD (applied on the PRIMARY LOADING AXIS) the LOAD CELL is designed to measure within its specifications.

RATED LOAD: See RATED CAPACITY

RATIONALIZATION: The process of adjusting the load cell OUTPUT RESISTANCE.

R.C.: See RATED CAPACITY

REFERENCE STANDARD: A force measuring device or quantity of mass whose characteristics are precisely known in relation to a primary standard.

REPEATABILITY ERROR: See NON-REPEATABILITY.

RESOLUTION: The smallest change in LOAD that produces a detectable change in the SIGNAL.

SAFE LOAD LIMIT: The MAXIMUM LOAD that can be applied without producing a permanent shift in the performance characteristics beyond those specified.

SENSE: The use of additional wires to measure the EXCITATION VOLTAGE applied to the LOAD CELL CIRCUIT at the load cell.

SENSITIVITY: The ratio of the change in OUTPUT to the change in LOAD.

SIDE LOAD: Any LOAD acting 90 degrees to the PRIMARY AXIS at the point of AXIAL LOAD application.

SIDE LOAD, SAFE: The SIDE LOAD that can be applied in any direction to the load cell, without producing permanent change in its stated specification [Expressed as a percentage of rated load]

SIDE LOAD, ULTIMATE: The SIDE LOAD in any direction that will not result in structural damage [Expressed as a percentage of rated load]

SIGNAL: (For Analog LOAD CELLS) The absolute level of measurable quantity produced at the SIGNAL terminals of the LOAD CELL.

STABILIZATION PERIOD: See WARM UP PERIOD.

STANDARD TEST CONDITIONS: The environmental conditions under which measurements should be made when measurements under any other conditions may result in

disagreement between various observers at different times and places.

These conditions are as follows:

Temperature: 20° +/- 2° C. (68° +/- 3.6° F)
Relative Humidity: 90% or less
Barometric Pressure: 98 +/- 10 kPa (29 +/- 3 inches Hg)

STRAIN GAGE: A device whose change in electrical resistance is a function of applied strain.

STRAIN GAGE LOAD CELL: A device which when mechanically loaded and electrically energized, produces an electrical SIGNAL, derived from a STRAIN GAGE(S), which is a function of applied load

SYMMETRY, ELECTRICAL: The difference of resistance of the LOAD CELL CIRCUIT measured from either excitation terminal to the output terminals connected together, resulting from the application of COMPENSATION.

TEMPERATURE EFFECT ON MINIMUM DEAD LOAD OUTPUT (TEM DLO): The change in MINIMUM DEAD LOAD output due to a change in ambient temperature. [Expressed in % of RATED OUTPUT

TEMPERATURE EFFECT ON RATED OUTPUT: The change of SIGNAL at RATED CAPACITY for a specified change of temperature at steady state temperature conditions. [Expressed as a percentage of APPLIED LOAD per °C]

TEMPERATURE EFFECT ON ZERO LOAD OUTPUT: See TEMPERATURE EFFECT ON MINIMUM DEAD LOAD OUTPUT.

TEMPERATURE RANGE, COMPENSATED: The range of temperature over which the LOAD CELL is compensated to meet all specification.

TEMPERATURE RANGE, SAFE: The extremes of temperature within which the LOAD CELL will operate without permanent adverse change to any of its performance characteristics, but may not meet specifications.

TEMPERATURE RANGE, OPERATING: See TEMPERATURE RANGE, COMPENSATED.

TEMPERATURE RANGE, STORAGE: The limits of temperature within which the load cell may be stored, without electrical excitation or mechanical loading without causing deterioration of stated specification.

TERMINAL RESISTANCE, INPUT: See INPUT RESISTANCE

TERMINAL RESISTANCE, OUTPUT: See OUTPUT RESISTANCE.

TERMINAL RESISTANCE, SYMMETRY: See SYMMETRY, ELECTRICAL.

TRACEABILITY: The step-by-step transfer process by which the LOAD CELL CALIBRATION can be related to primary standards.

UN-BALANCED COMPENSATION: The application of COMPENSATION circuitry to only one EXCITATION arm of the WHEATSTONE BRIDGE.

WARM UP PERIOD: The period of time in which the load cell achieves and maintains a stable state of its ZERO LOAD OUTPUT, with all environmental conditions and other variables remaining constant.

WHEATSTONE BRIDGE: The electrical arrangement of circuitry within a STRAIN GAUGE LOAD CELL where by the LOAD CELL CIRCUIT is unbalanced during application of load to produce SIGNAL when an EXCITATION VOLTAGE is applied.

ZERO BALANCE: See ZERO LOAD OUTPUT.

ZERO FLOAT: The ZERO SHIFT caused by one complete cycle of tensile and compressive RATED LOAD. [Expressed as a percentage of rated output.]

ZERO LOAD OUTPUT: The SIGNAL from the load cell at zero load. [Expressed as a percentage of rated output.]

ZERO SHIFT: A change in the ZERO LOAD OUTPUT.

ZERO STABILITY: The degree to which the LOAD CELL maintains its ZERO LOAD OUTPUT over a specified period of time with all environmental conditions and other variables remaining constant.

REFERENCES

- 1) Kent's Mechanical Engineer's Handbook.
- 2) Guide for Load Cells, WELMEC European cooperation in legal metrology.
- 3) A Procedure for the Specification, Calibration and Testing of Strain Gauge Load Cells for Industrial Process Weighing and Force Measurement, Institute of Measurement & Control, London.
- 4) NCWM Publication 14, National Type Evaluation Program Administrative Procedures, Technical Policy, Checklists, and Test Procedures, Section 2, Chapter 5, Checklist for Load Cells
- 5) OIML International Recommendation R 60, Metrological regulation for load cells

End

of

Document